

# SERIES A, S, & H

## NOISE ATTENUATION ACOUSTIC DIFFUSERS

INSTRUCTION PART NO. 1465701

REVISION N/A

**WARNING** - Before proceeding with installation, make sure isolation valves have been closed and the steam supply has been shut off.

1. Ensure the piping is free from foreign material before the pressure reducing valve.
2. Install the pressure reducing valve in accordance with the instructions supplied with the valve.
3. Connect the inlet of the noise diffuser directly to the outlet flange of the pressure reducing valve to avoid the generation of flanking noise.
4. Provide a length of at least 10 pipe diameters of pipe equal to the nominal size of the diffuser outlet. If desired, piping may then be reduced to a smaller size as long as flow velocity does not exceed 6,000 feet per minute.
5. Ensure the piping is adequately supported to avoid imposing stress on the valve body or the diffuser.
6. The typical hook-up shown below will aid in planning a correct installation.

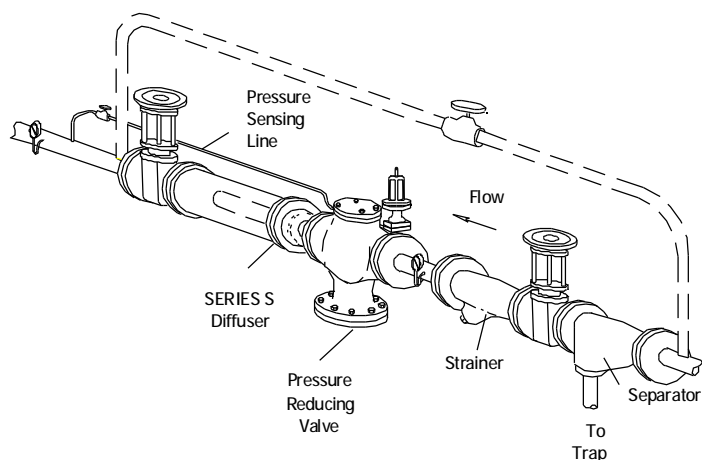

### ORIFICE PLATE

Noise  
Reduction  
5-10 dBA

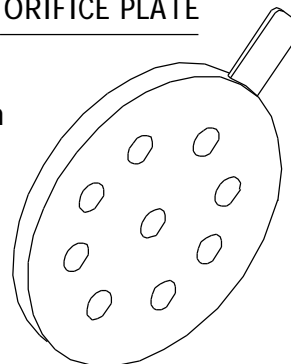

### SERIES A

### ACOUSTIC DIFFUSER

Noise  
Reduction  
10-15 dBA

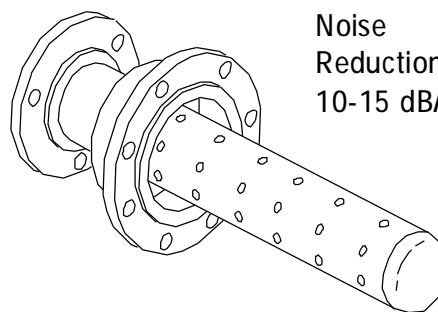

### SERIES S

### ACOUSTIC SILENCER

Noise  
Reduction  
20-30 dBA

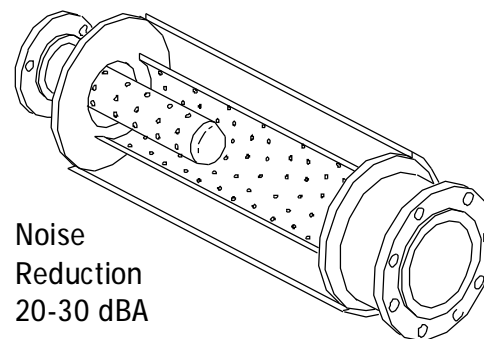

### SERIES H

Each Watson McDaniel Company Product is warranted against defects in material and workmanship for one year from date of shipment. This warranty extends to the first retail purchaser only. All defective material must be returned to the person from whom you purchased the Product, transportation prepaid, free of any liens or encumbrances, and if found to be defective will be repaired free of charge or replaced, at the warrantor's or seller's option. If the material is replaced, any replacement will be invoiced in the usual manner and after inspection of alleged defective material an adjustment will be made for depreciation caused by purchaser's use. In no event will Watson McDaniel Company be liable to do more than refund the original contract price. Incidental and consequential damages are excluded, whether under this warranty or otherwise. All implied warranties, including warranties of merchantability and fitness for a particular purpose, are disclaimed and excluded.