

**INSTALLATION**

The WSSCV in line check valve can be installed in any orientation. Use pipe dope or teflon tape on pipe joints. The flow arrow on the body must be pointed in the direction of flow.

**MAX. ALLOWABLE CONDITIONS**

PMA	750 PSIG @ 100°F
TMA	850°F @ 420 PSIG

**SERVICE**

Should dirt, trash or other foreign matter become lodged between the sealing surfaces and cause the valve to leak, flush the valve with clean water. Replace the valve if it continues to leak.

It may become necessary to install a strainer before the check valve if dirt becomes a problem.

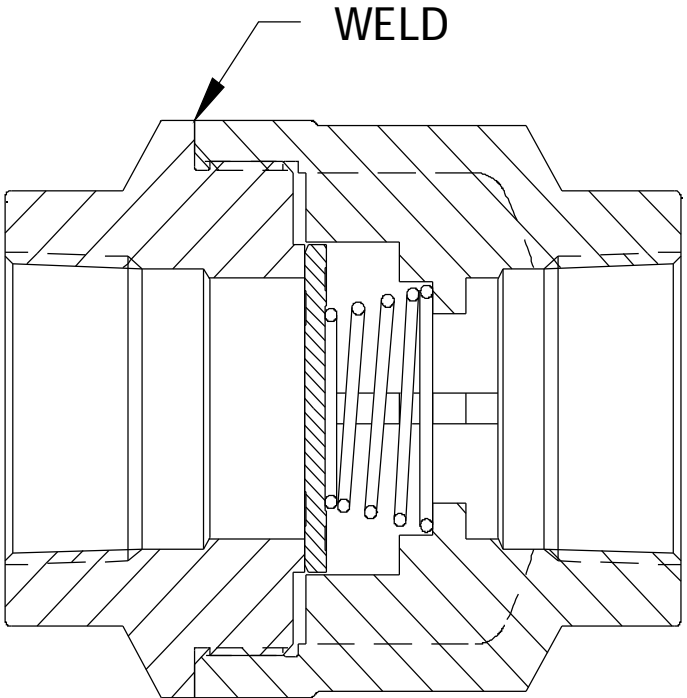

Each Watson McDaniel Company Product is warranted against defects in material and workmanship for one year from date of shipment. This warranty extends to the first retail purchaser only. All defective material must be returned to the person from whom you purchased the Product, transportation prepaid, free of any liens or encumbrances, and if found to be defective will be repaired free of charge or replaced, at the warrantor's or seller's option. If the material is replaced, any replacement will be invoiced in the usual manner and after inspection of alleged defective material an adjustment will be made for depreciation caused by purchaser's use. In no event will Watson McDaniel Company be liable to do more than refund the original contract price. Incidental and consequential damages are excluded, whether under this warranty or otherwise. All implied warranties, including warranties of merchantability and fitness for a particular purpose, are disclaimed and excluded.