

SERIES WLDI400

FLOAT TYPE LIQUID DRAIN TRAP

INSTALLATION INSTRUCTIONS

INSTRUCTION PART NO. 2365600 REVISION 0

INSTALLATION

1. Before installing the drainer, blow out piping thoroughly to remove loose scale and dirt. Use pipe dope or teflon tape sparingly when attaching the drainer to the pipe. Observe the pressure limitation shown on the drainer label.
2. Install the drainer in a horizontal pipeline below the equipment being drained in a location easily accessible for maintenance and inspection. Be certain the 2" drainer is supported under the body.
3. Install a drip pocket to keep dirt away from the drainer.
4. Discharge piping should be amply sized to avoid excessive back pressures.
5. To provide for easy maintenance and service, install a block valve on each side of the drainer and install a strainer ahead of the inlet connection.
6. All valves should be full ported to achieve the rated capacity of drainer.
7. If the discharge piping is to be elevated, be certain that the available differential pressure is adequate to permit proper drainage. Remember, two feet of lift equals approximately one psig.
8. Float style Liquid Drainers require a balance line as illustrated. On pressure vessel applications, the balance line connection should be above the liquid level. On separators, that connection should be made on down stream side.

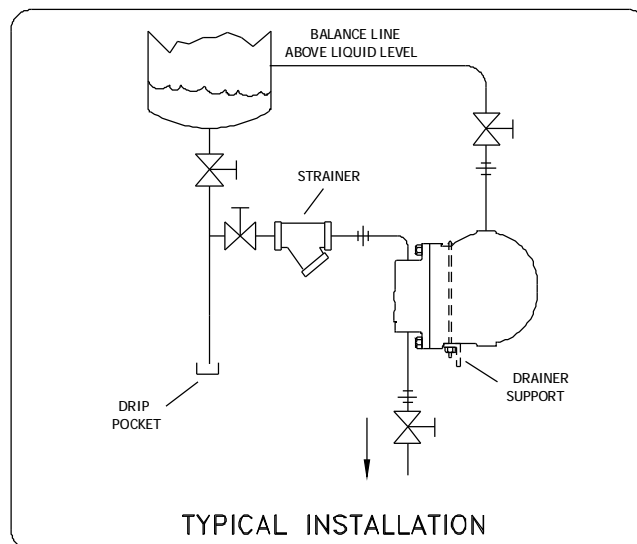
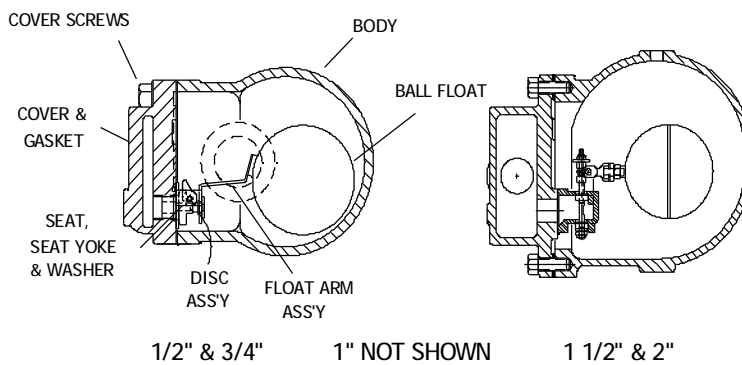

MAX. OPERATING CONDITIONS

- PMO 300 psig
- TMO 450 °F
- PMA 300 psig up to 450°F
- TMO 450 °F @ 300 PSIG

TROUBLESHOOTING

PROBLEM	CAUSE	ACTION
1) Drainer does not discharge.	a) Damaged float. b) Operating pressure too high.	a) Replace float. b) Install drainer suitable for operating pressure
2) Drainer does not close.	a) Dirt lodged on seat. b) Worn out internal.	a) Clean drainer; install strainer. b) Replace internals; be certain to match the model number and pressure

ORDERING SPARE PARTS

Specify the description of the part. Indicate the Model Number, Size and Operating Pressure, which are shown on the name plate.

Typical Specification: Cover & Gasket for 2" WLD 1400 Liquid Drainer.

Each Watson McDaniel Company Product is warranted against defects in material and workmanship for one year from date of shipment. This warranty extends to the first retail purchaser only. All defective material must be returned to the person from whom you purchased the Product, transportation prepaid, free of any liens or encumbrances, and if found to be defective will be repaired free of charge or replaced, at the warrantor's or seller's option. If the material is replaced, any replacement will be invoiced in the usual manner and after inspection of alleged defective material an adjustment will be made for depreciation caused by purchaser's use. In no event will Watson McDaniel Company be liable to do more than refund the original contract price. Incidental and consequential damages are excluded, whether under this warranty or otherwise. All implied warranties, including warranties of merchantability and fitness for a particular purpose, are disclaimed and excluded.