



428 Jones Boulevard Phone: (610)495-5131  
 Limerick Airport Business Center Fax: (610)495-5134  
 Pottstown, PA 19464 www.watsonmcdaniel.com

# SUCTION/MIXING TEE INSTALLATION INSTRUCTIONS

INSTRUCTION PART NO. 2366900

REVISION 0

## TYPICAL APPLICATION

The Watson McDaniel cast iron, bronze or stainless steel Suction Tee is a specialized type of pipe fitting used for blending, agitation, recirculation, mixing, aeration and heating.

## HOW IT WORKS

### Heating by Direct Steam Injection:

When using a Suction Tee for heating by direct steam injection, the Suction Tee must be completely submerged in the liquid being heated. When steam enters the primary inlet side of the Suction Tee body, a low pressure condition is created inside the Suction Tee body. This causes the liquid inside the tank to circulate through the suction tee and intermix with the steam causing the liquid to be heated.

## MIXING

When liquid is pumped through the primary inlet of a Suction Tee, a low pressure region is created inside the Suction Tee body. When a Suction Tee is submerged, the liquid inside the tank will circulate through the secondary inlet of the Suction Tee causing a mixing action to occur. An alternate method when mixing two different liquids is to pump one liquid through the primary side and the other liquid through the secondary side of the Suction Tee.

## AERATION

A tank or reservoir of liquid can be aerated by connecting the secondary inlet of the Suction Tee to an air or gas line under pressure while pumping liquid through the primary inlet.

## INSTALLATION

Installation should include a strainer and isolation valves for maintenance purposes.

### PRESSURE TEMPERATURE RATINGS

Cast Iron NPT	250 PSIG @ 406°F
Bronze NPT	300 PSIG @ 422°F
Stainless Steel NPT	450 PSIG @ 400°F

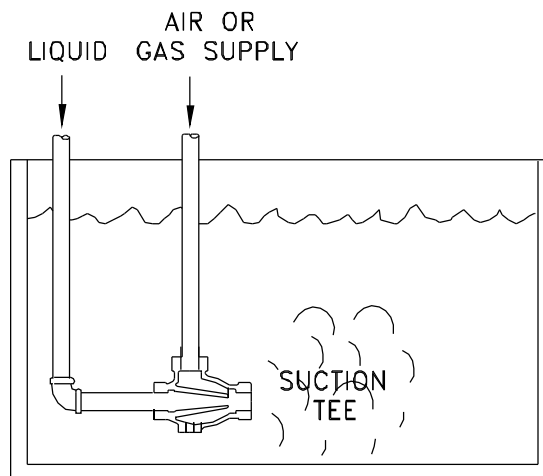
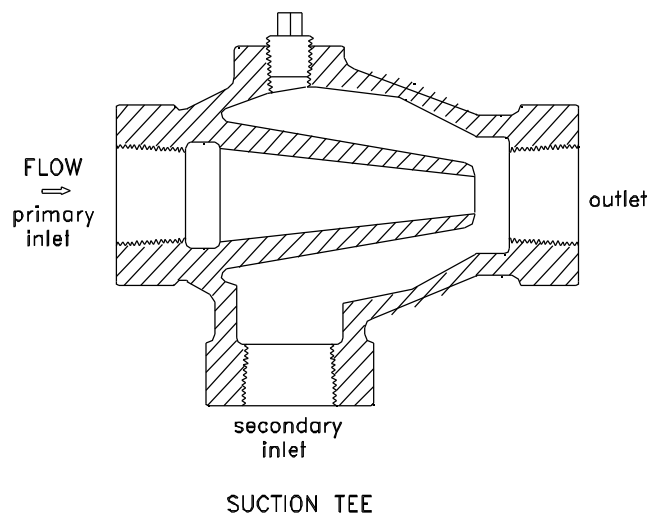

AERATION OF AGITATION

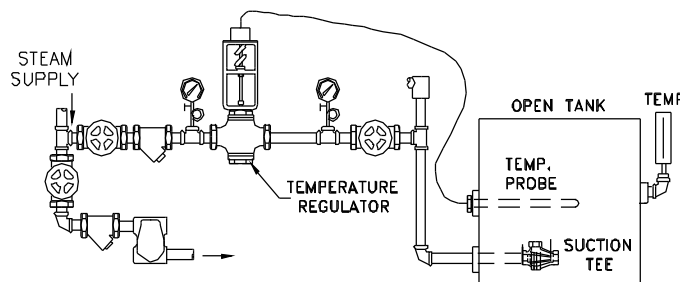

CONTROLLING TEMPERATURE OF LARGE OPEN TANK BY STEAM INJECTION

Each Watson McDaniel Company Product is warranted against defects in material and workmanship for one year from date of shipment. This warranty extends to the first retail purchaser only. All defective material must be returned to the person from whom you purchased the Product, transportation prepaid, free of any liens or encumbrances, and if found to be defective will be repaired free of charge or replaced, at the warrantor's or seller's option. If the material is replaced, any replacement will be invoiced in the usual manner and after inspection of alleged defective material an adjustment will be made for depreciation caused by purchaser's use. In no event will Watson McDaniel Company be liable to do more than refund the original contract price. Incidental and consequential damages are excluded, whether under this warranty or otherwise. All implied warranties, including warranties of merchantability and fitness for a particular purpose, are disclaimed and excluded.